

SNH – Emergency stop buttons



Applications

- Machine and plant manufacturing
- Building machinery and transport technology

Features

- For applications up to IP69K
- Tamper-proof according to EN 418/EN ISO 13850
- Modular design
- Turn-to-reset
- Integrated illumination
- Optical indication of the switching state
- Up to PL e/Category 4 (EN ISO 13849-1)
- Up to SIL_{CL} 3 (EN 62061)

Function

Emergency stop buttons of the SNH series are used on or near machines for the protection of persons. They serve the purpose of switching off / stopping machines and systems to avoid or reduce emerging or existing hazards to persons. Emergency stop buttons of the SNH series are also used to avoid damage to the machine or working material.

- **Modular design** – The emergency stop buttons of the SNH series have a modular design, various actuating elements can be freely combined with the chosen contact design.
- **Failure protection** – The emergency stop buttons of the SNH series have a special failure protection that automatically detects when a contact block is removed from the respective actuating element and then switches off safely.

Dimension diagram

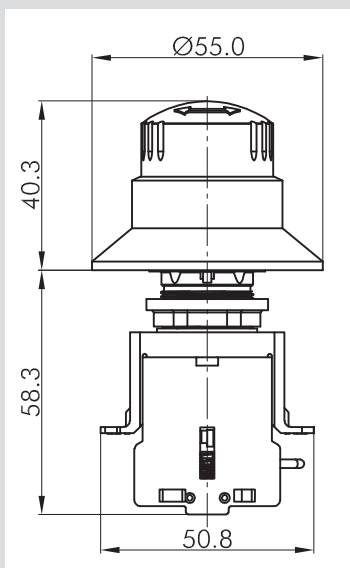

Cut-out dimensions

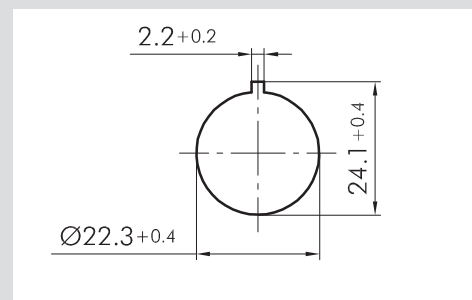

SNH – Emergency stop buttons

Technical data

Function	
According to EN 418/EN ISO 13850	Emergency stop button
Actuator	
Housing material	Plastic
Protection degree	IP 65
Operating ambient temperature	-30 – +70 °C (without illumination), -30 – +55 °C (with illumination)
Storage temperature	-50 – +85 °C
Switching cycles	> 50000
Max. torque	2.5 Nm
Installation diameter	22.3 mm
Contact blocks	
Contact type	NC contact NC contact with failure protection NO contact
Contact material	AgNi
Switching principle	Slow-action contact
Actuating travel	6 mm
Mechanical service life	1 x 10 ⁷ switching cycles
Electrical service life	1 x 10 ⁸ switching cycles
Application category	AC15 A600: 250 V, 3A DC13 Q600: 24 V, 2A
Protection class	II
Rated insulation voltage	600 V
Min. Switching voltage	5 V
Min. Switching current	1 mA
Thermal continuous current I _{th}	16 A
Max. through-type thermistor	20 mΩ
Max. bounce time	20 ms
Min. positive opening travel	3 mm
Operating ambient temperature	-30 – +85 °C
Storage temperature	-50 – +85 °C
Connection technology	Screw connection
Conductor cross-section	Max. 2,5 mm ²
Standards	EN 418 /EN ISO 13850
Approvals	TÜV, cULus

SNH – Emergency stop buttons

Contact blocks



SNH 0001



SNH 0002

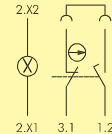

SNH 0003

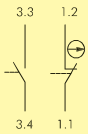

SNH 0011

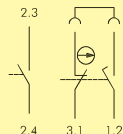

SNH 0012

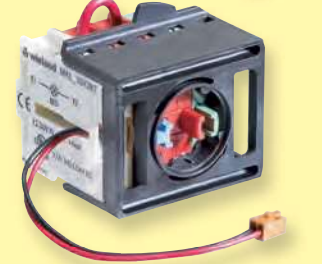
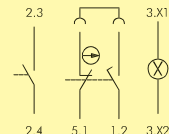

SNH 0013

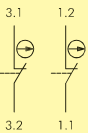

SNH 0021

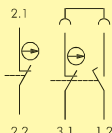

SNH 0022

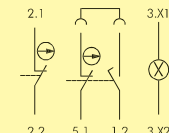

SNH 0023

Actuating elements



SNH 0100

SNH 0400 (with illumination)



SNH 0200



SNH 0300

(up to IP 69K)



SNH 0500



SNH – safe.

SNH – Emergency stop buttons

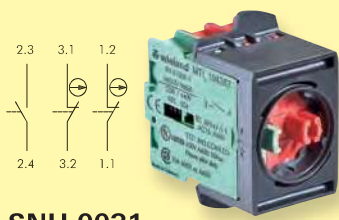

SNH 0031

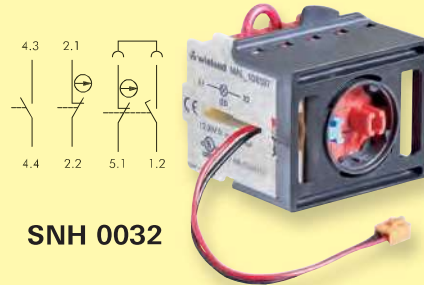

SNH 0032

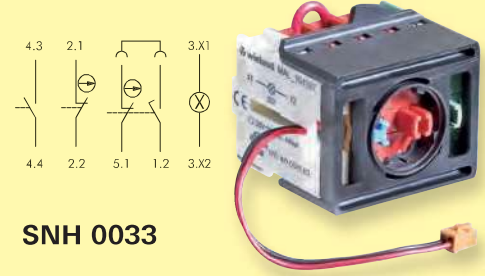

SNH 0033

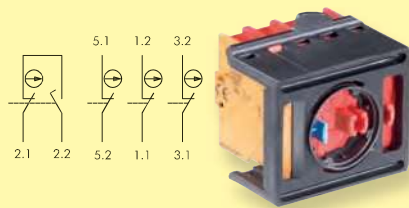

SNH 0043

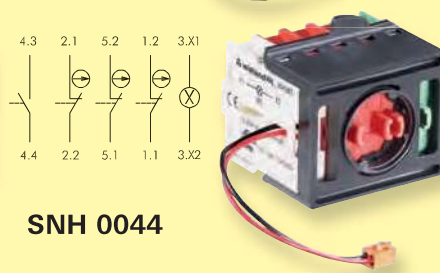

SNH 0044



SNH 0600



SNH 0700

Housing



SNH 6001



simple. modular.



SNH – Emergency stop buttons

Dimension diagram

Actuating elements

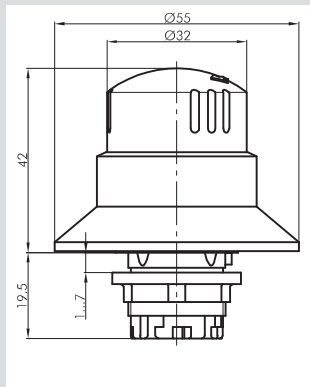

SNH 0100
SNH 0400

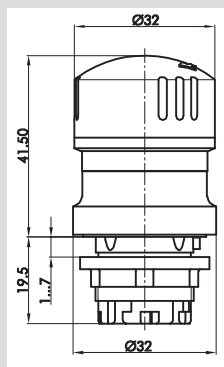

SNH 0200

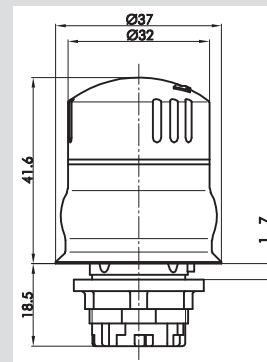

SNH 0300

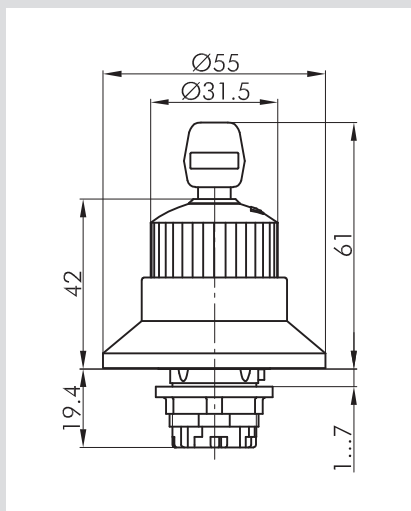

SNH 0500

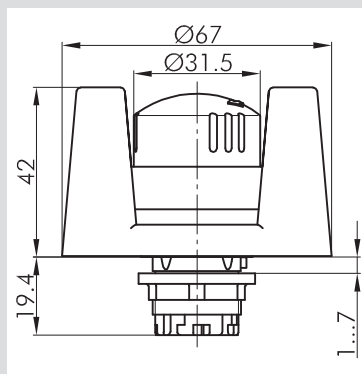

SNH 0600

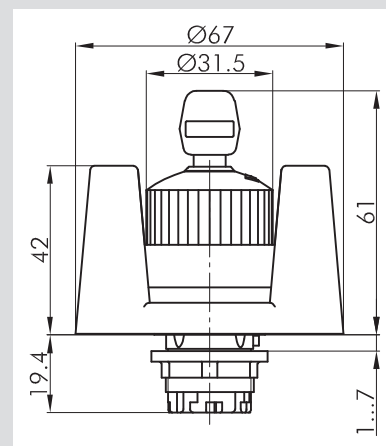

SNH 0700

Housing

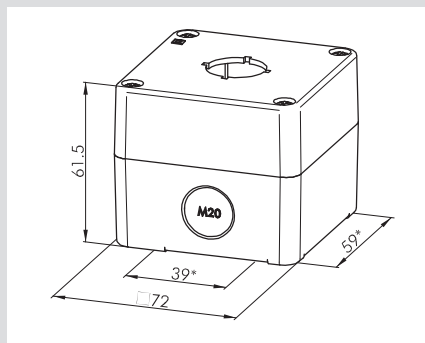

SNH 6001

SNH – Emergency stop buttons

Dimension diagram

Contact blocks

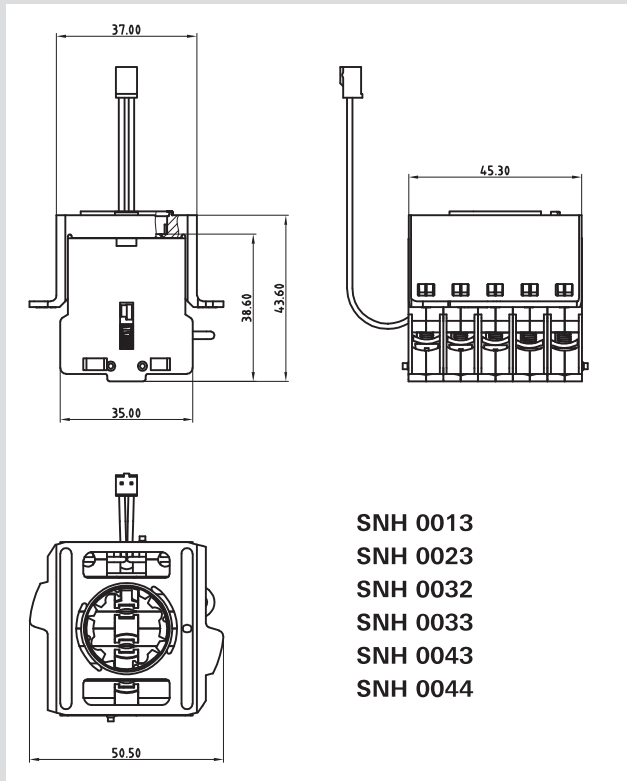

- SNH 0013
- SNH 0023
- SNH 0032
- SNH 0033
- SNH 0043
- SNH 0044

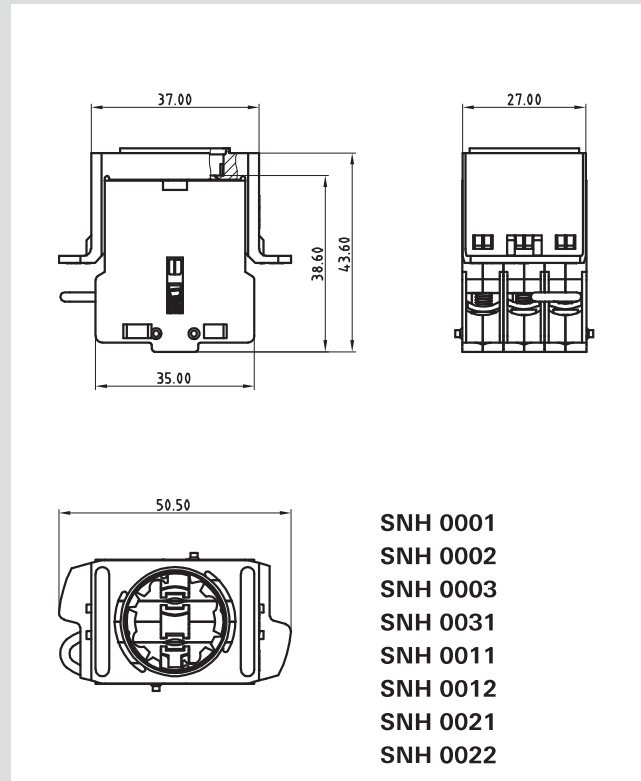

- SNH 0001
- SNH 0002
- SNH 0003
- SNH 0031
- SNH 0011
- SNH 0012
- SNH 0021
- SNH 0022

Overview of devices | part numbers

Type	Description	Part no.	Std. pack
SNH 0001	Contact block, 1 NC	R1.200.0001.0	1
SNH 0002	Contact block, 1 NC (failure protection)	R1.200.0002.0	1
SNH 0003	Contact block, 1 NC (failure protection) / illumination	R1.200.0003.0	1
SNH 0011	Contact block, 1 NC / 1 NO	R1.200.0011.0	1
SNH 0012	Contact block, 1 NC (failure protection) / 1 NO)	R1.200.0012.0	1
SNH 0013	Contact block, 1 NC (failure protection) / 1 NO / illumination	R1.200.0013.0	1
SNH 0021	Contact block, 2 NC	R1.200.0021.0	1
SNH 0022	Contact block, 2 NC (failure protection)	R1.200.0022.0	1
SNH 0023	Contact block, 2 NC (failure protection) / illumination	R1.200.0023.0	1
SNH 0031	Contact block, 2 NC / 1 NO	R1.200.0031.0	1
SNH 0032	Contact block, 2 NC (failure protection) / 1 NO)	R1.200.0032.0	1
SNH 0033	Contact block, 2 NC (failure protection) / 1 NO / illumination	R1.200.0033.0	1
SNH 0043	Contact block, 4 NC (failure protection)	R1.200.0043.0	1
SNH 0044	Contact block, 3 NC / 1 NO / illumination	R1.200.0044.0	1
SNH 0200	Actuator (with actuation indication)	R1.200.0200.0	1
SNH 0300	Actuator IP69 (without actuation indication)	R1.200.0300.0	1
SNH 0100	Actuator (with actuation indication)	R1.200.0100.0	1
SNH 0400	Actuator (with actuation indication + illumination)	R1.200.0400.0	1
SNH 0500	Actuator (with actuation indication + key release)	R1.200.0500.0	1
SNH 0600	Actuator (with actuation indication + protective collar)	R1.200.0600.0	1
SNH 0700	Actuator (with actuation indication, protective collar and key release)	R1.200.0700.0	1
SNH 1101	Emergency stop button (SNH 0100, 1 NC)	R1.200.1101.0	1
SNH 1102	Emergency stop button (SNH 0100, 1 NC (failure protection))	R1.200.1102.0	1
SNH 1111	Emergency stop button (SNH 0100, 1 NC / 1 NO)	R1.200.1111.0	1
SNH 1112	Emergency stop button (SNH 0100, 1 NC (failure protection) / 1 NO)	R1.200.1112.0	1
SNH 1121	Emergency stop button (SNH 0100, 2 NC)	R1.200.1121.0	1
SNH 1122	Emergency stop button (SNH 0100, 2 NC (failure protection))	R1.200.1122.0	1
SNH 1131	Emergency stop button (SNH 0100, 2 NC / 1 NO)	R1.200.1131.0	1
SNH 1132	Emergency stop button (SNH 0100, 2 NC (failure protection) / 1 NO)	R1.200.1132.0	1
SNH 1143	Emergency stop button (SNH 0100, 4 NC (failure protection))	R1.200.1143.0	1
SNH 6001	Housing IP67	R1.200.6001.0	1
SNH 6010	Emergency stop adhesive plate	R1.200.6010.0	10